

OPERATING MANUAL
for
ARRIFLEX® 16S
(STANDARD)

The following diagram pages may be kept folded out for your convenience in identifying operating parts while reading the instructions.

DIAGRAM OF ARRIFLEX 16 S (Standard)

showing external controls and features

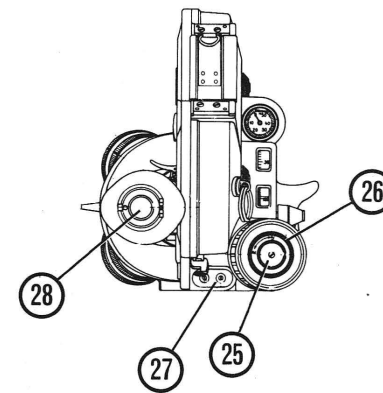
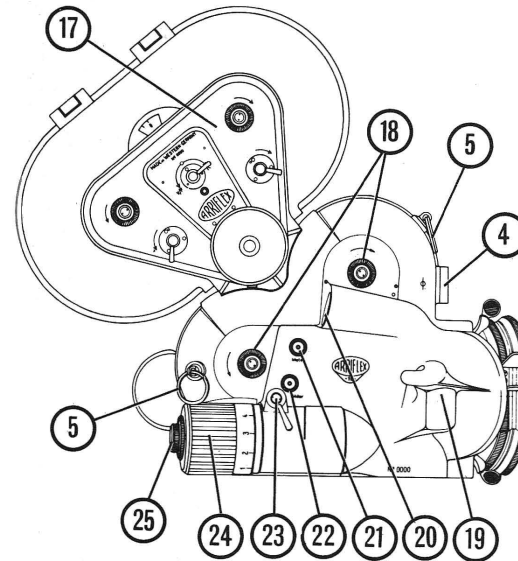
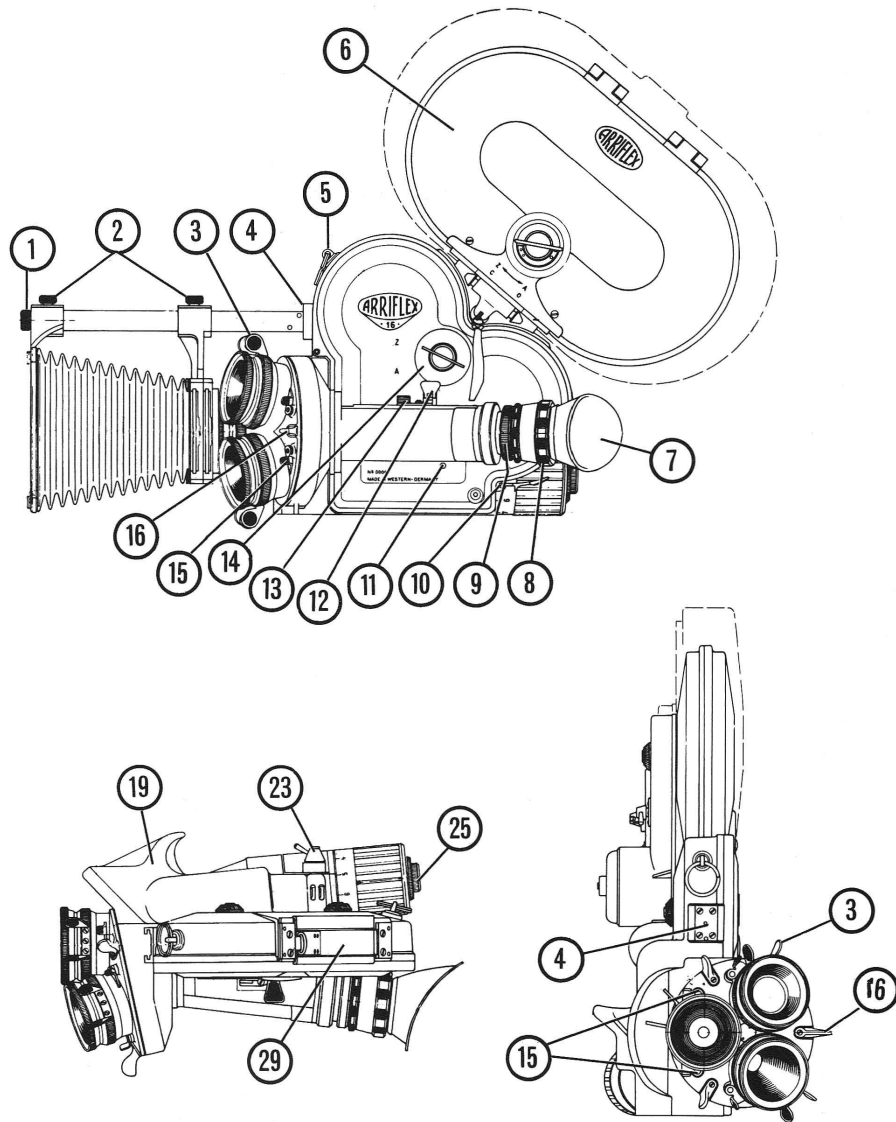

- 1) Lock screw for matte box boom
- 2) Lock screws for adjusting front and rear matte box standards
- 3) Follow focus wings on each lens
- 4) Slide-in shoe for matte box
- 5) Eyelet for attaching shoulder strap
- 6) Interchangeable magazine 200 or 400 ft.
- 7) Finder eyepiece with rubber eyecup
- 8) Diopter adjustment ring
- 9) Knurled ring for removing eyepiece
- 10) Battery cable lock
- 11) External buckle switch override
- 12) Locking start/stop switch
- 13) Lock release for switch
- 14) Cover lock
- 15) Lens socket lock levers (1 of 6)
- 16) Turret grip (1 of 3)
- 17) Interchangeable torque motor (only one needed for camera)
- 18) Feed- and take-up spindles
- 19) Contour grip with thumb rest
- 20) Tachometer
- 21) Footage counter setting disk
- 22) Frame counter setting disk
- 23) Motor lock
- 24) Interchangeable motor
- 25) Knob for manually turning motor
- 26) Forward and reverse switch for variable speed motor
- 27) Battery cable socket
- 28) Light cover in finder eyepiece in closed position
- 29) Magazine cavity cover

C O N G R A T U L A T I O N S !

You now own an ARRIFLEX, one of the finest, most versatile motion picture cameras ever made.

Soon this new ARRIFLEX will be at work for you. We know it will perform to your entire satisfaction.

As a member of the ARRIFLEX family, you are cordially invited to call on us at any time for advice or assistance. If you use the ARRIFLEX in a particularly interesting, complicated, difficult or unusual application, won't you please write to us about it? We will be glad to hear from you.

I M P O R T A N T

Please be sure to fill out and mail the guarantee card which accompanies your camera. This not only makes the guarantee valid, but it also permits us to serve you better should you have any technical or service problems in the future.

As we keep a permanent record of all registration cards, we can also help you better in case of theft.

Each ARRIFLEX 16 S is S U P P L I E D W I T H :

- 1) Test Film taken with camera
- 2) Battery cable with attached ground connector cable for torque motor
- 3) Sturdy leather shoulder strap
- 4) Fountain-pen type brush for cleaning optical surfaces (when cap is put on rear of brush holder, brush is pushed out)
- 5) Plastic skewer for cleaning emulsion from film gate
- 6) Bottle with special camera oil
- 7) Tube of special grease for lens cavities of camera and lens mounts
- 8) Pressure oiler
- 9) Guarantee Card
- 10) Instruction Manual

OPERATING INSTRUCTIONS FOR
ARRIFLEX 16 S
(Standard)

HOLDING CAMERA

Place thumb of right hand between contour grip and side of camera, while the other fingers reach forward around the "bulge" where they are free to actuate the follow-focus grips and diaphragm ring of the lens in taking position.

Place palm of left hand around finder housing on left side of camera, fingers over ON-OFF switch. Thus camera can be held steady easily and comfortably.

When switch is pressed down, it remains locked in down-position until its release lever is pushed in.

An accessory PISTOL GRIP with or without shoulder brace is also available. It is attached to the tripod socket and has its own release trigger which connects through switch behind tripod socket. (See separate instructions for Pistol Grip).

SIGHTING

Place right eye against finder eyecup. An eyeglass wearer should raise his glasses to his forehead and sight without them. For left eye viewing, the eyecup may be turned around. (Click-stops!)

If shutter is closed, turn transport knob in center of motor to open it.

First focus eye to ground glass by turning the knurled adjustment ring at the eyepiece until grain structure of ground glass appears sharp. You may want to do this without lens in socket. The adjustment ring should then be locked in place by either of the lock levers.

Then focus on subject by actuating focusing mount of lens. For critical sharpness, always focus lens with diaphragm wide open. This is important to remember as the optical system of the Arriflex finder is so bright that a brilliant image can be seen even when lens is stopped down.

Most Arriflex lenses have clicking diaphragm stops so that the lens can be stopped down without removing camera from eye.

INSTRUCTIONS FOR ARRIFLEX 16S

While the optical system of the finder is constructed so that it prevents light from entering and fogging film, the eyepiece must be shielded from direct (horizontal) sunlight or powerful spotlight if eye is removed. For this purpose a light cover is provided inside the rubber eyecup. During filming always press eye firmly against eyecup or close the cover door on the eyepiece.

FINDER WITH DETACHABLE EYEPIECE AND INTERCHANGEABLE GROUND GLASS

The detachable eyepiece permits using the camera in the Arriflex 16 BLIMP without the eyepiece while attaching the eyepiece on the outside of the BLIMP.

It also permits attaching the PERISCOPIC ACCESSORY FINDER, which facilitates viewing from the side or the top (for instance if camera is on a microscope or copy stand), or viewing with the left eye when a 400-ft. MAGAZINE is attached to camera (See illustration in Arriflex folder).

The eyepiece can be removed by turning the knurled chrome-plated collar clockwise (camera in shooting position). To replace it, engage keyed flange properly and turn collar counter-clockwise.

The rubber eyecup can be turned freely on its click-stop bearing for right or left eye viewing.

The eyepiece cover door also turns freely and should always be set to open along long end of rubber cup.

The standard ground glass, supplied with the camera, can be interchanged with SPECIAL GROUND GLASSES with cross hair reticle, or TV field, or clear glass with reference reticle for cinemicroscopy (See price list for details). (Such installations are a service department job and must be done only by skilled, experienced technicians with special tools).

The Arriflex eyepiece has a high accommodation diopter adjustment-collar with lock lever. For people, whose eyesight requires further correction, it is possible to fit PRESCRIPTION LENSES into the eyepiece. (Write for further information).

Another worthwhile accessory is the FOAM RUBBER EYE CUSHION which fits over the rubber eyecup. It is particularly convenient in perspiring hot weather and it is also desirable when different cameramen use the same camera. Each cameraman can have his own eye cushion.

MIRROR REFLEX SHUTTER

The mirror reflex shutter is the heart of the Arriflex. It rotates at a 45° angle between lens and film plane and reflects upon the ground glass of the viewfinder exactly the same image as is registered on the film. The light rays reach the film through the lens without any interference while the shutter is open; they are reflected to the ground glass only while the shutter is closed. Thus the film, as well as the eye, always get 100 % of the light transmitted by the taking lens.

The shutter opening of 180° results in the following exposures:

<u>Camera Speed</u>	<u>Exposures</u>
8 FPS	1/16 sec.
12 FPS	1/24 sec.
16 FPS	1/32 sec.
24 FPS	1/48 sec.
32 FPS	1/64 sec.
48 FPS	1/96 sec.

As this table indicates, the exposure can be calculated for any camera speed by doubling the FPS figure and reading the result as a fraction of a second.

TURRET

The Arriflex 16 features a heavy duty three-lens turret. The lenses are mounted in a divergent manner (21°) to prevent optical and mechanical interference between wide-angle and telephoto lenses. Thus a 16mm wide-angle lens can be mounted simultaneously with a 300mm (12") Tele-Kilar without danger of interference.

It features the same lens mounts as the Arriflex 35, whose advantages are their positive locking device, the speed and ease of changing lenses, and the large seating ring, which permits even relatively long and heavy lenses to be attached accurately and securely. Very long or heavy lenses, of course, must always be supported by means of a proper ARRI LENS CRADLE (Accessory Item).

Three turret grips make it easy to rotate the turret which comes to a positive stop whenever a lens socket is over the film aperture. Never grasp lenses for the purpose of turning turret around!

The lens located nearest the contour grip on the right side of the camera is in the taking position.

The back of each grip - protruding on left side of camera and visible with the left eye, while the right eye is looking through the finder - is coded with one, two, or three dots to indicate if wide-angle, normal, or telephoto lens is in taking position.

To remove lens from turret press the two spring-loaded locking levers at the base of the lens socket together, with thumb and index finger of one hand, while lifting lens out with the other.

To insert lens, again press locking levers together and place lens into socket. Align the channel in lens mount with the guide key in the socket. Release the levers and the lens is locked into position.

LENSES FOR ARRIFLEX 16

are made by the world's best optical manufacturers and represent the ultimate in quality. The lenses available for the Arriflex 16 range in focal length from 5.7mm up. The standard lenses are equipped with follow-focus grips and most have diaphragm click-stops. Thus the lens can be stopped down from behind the camera without direct observation.

With due consideration for the professional use for which they are intended, all Arriflex lenses are triple-checked for best optical performance before they are mounted for the Arriflex; only the very finest lenses are selected. (See Arriflex price list for makes, focal lengths and maximum apertures).

Among telephoto lenses, we recommend the KILFITT KILARS available up to 600 mm. They are of outstanding quality and workmanship. The relatively low cost of these lenses is due only to the fact that they can be manufactured in large quantities as they are primarily made for 35mm still cameras. All KILARS feature a removable Arriflex mount. EXTENSION TUBES and VARIABLE HELICAL EXTENSION ADAPTERS are available for filming at extremely close distances (Macro Cinematography).

For close-up work, the Kilfitt MAKRO-KILAR lenses are ideal. The Kilfitt 90 mm Makro-Kilar focuses continuously from infinity to 8" from the subject. The 40 mm Makro-Kilar focuses from infinity to 4".

A variety of variable focal length ("Zoom") lenses are also available which are manufactured to Arriflex specifications and standards. (See price list for details). With your Arriflex 16 these lenses require no special finder. The field size, focus and depth of field are always clearly shown in the camera's unique mirror-shutter reflex system.



LENS SELECTION

It is the factory's policy to sell Arriflex cameras only complete with top quality lenses. Inferior lenses mounted on these cameras would not only nullify the great expense of precision engineering that goes into each camera, but would not yield the superb results of which the Arriflex is capable.

The standard set of lenses for the Arriflex 16 is usually of 16mm, 25mm, and 50mm focal length. These lenses are used most frequently by professional cameramen and work best with the matte box.

When a longer focal length lens is mounted on the turret, the matte box often cannot be brought close enough to the 16mm or 25mm lenses to work properly, and the lens must therefore first be removed when using the 16mm or 25mm lens.

Whenever a lens socket is empty, it must be capped with a cavity cap which is supplied with the camera.

Extremely long or heavy lenses may require a cradle or other special support

CAUTION : When buying additional lenses for your Arriflex in the future, insist on "genuine" Arriflex lenses. Not every lens in Arriflex mount is genuine. It would be false economy to pay for mechanical Arriflex camera perfection and to jeopardize the investment with "orphaned" lenses that are frequently of poor optical quality, poorly mounted, poorly centered, and that are too expensive at any price. If in doubt whether a lens is genuine, please write to us, mentioning make and serial number.

DETACHABLE BELLOWS TYPE MATTE BOX AND FILTER HOLDER

This indispensable accessory fits over the lens turret. To attach the camera, slide the end of the boom into the special shoe on the front of the camera housing; it is tightened and locked into position by turning the knurled knob at the front of the boom.

The rear standard of the matte box is movable to accommodate lenses of various lengths. Its front is also adjustable to give maximum efficiency and to prevent vignetting irrespective of the lens used.

SPECIAL EFFECT MATTES (Accessory Item - see price list) can be inserted into the front frame.

INSTRUCTIONS FOR ARRIFLEX 16S

The two filter stages accept rectangular ARRI OPTICAL GLASS FILTERS, or ARRI FILTER HOLDER with frame for 2" square Kodak gelatine or glass filters.

One of the stages can be rotated for use with GRADUATED or POLARIZING FILTERS. (For available filters see price list).

The rear opening of the matte box is threaded to accept a screw-in adapter ring for circular Series VIII glass-mounted filters.

Use of the matte box improves picture quality considerably; never shoot without it ! In addition, it permits one filter to be used with most lenses.

MOTORS

An 8 Volt VARIABLE SPEED MOTOR is generally used with the Arriflex 16. After opening lock lever, the motor may be pulled out of the camera housing and interchanged with other motors - GOVERNOR CONTROLLED CONSTANT SPEED MOTOR, SYNCHRONOUS MOTOR, ANIMATION MOTOR. When variable speed motor is put back into place, care must be taken to line up the locating pin against the keyway in body casting and pushing it all the way in, as otherwise it will not make contact.

By turning the motor shell, a built-in rheostat is actuated that regulates the speed of the motor, which - in turn - can be read in frames per second on the tachometer. The figures around the motor shell are arbitrary ones, and after a little experience permit the operator to reset the camera quickly for any desired speed. (With a fully charged 8 Volt battery the rheostat will be set between 3 and 4 to give 24 FPS).

Other motors available in the Arriflex program are GOVERNOR CONTROLLED MOTOR, SYNCHRONOUS MOTOR, and TIME LAPSE MOTOR. (See price list and illustrated Arriflex folder).

All motors are interchangeable instantly without the need of tools.

POWER SOURCES / BATTERIES

IMPORTANT: Power requirements for Arriflex 16 with 400 ft. magazine are:

8 Volts (under load); 3.6 Amperes running;
starting surge up to 6 Amperes.

It is vital that the source of electric power be fully capable of delivering this current.



"VOLTABLOC" BATTERIES

These are steel-cased, longlife Nickel Cadmium batteries in which the electrolyte is an alkaline. Each cell is hermetically sealed and never requires the addition of water or the usual battery maintenance. Each battery is supplied complete with a miniature charger built into the case. - Dollar for Dollar it is probably the best buy. - The following two models are available :

7 V O 4 - D 8.4 Volt 4AH . It will run the Arriflex 16 for approximately 1000 ft. of film.

14 V O 4 - D It has a selector switch which permits drawing
8.4 Volt 8AH for use with Arriflex 16
16.8 Volt 4 AH for use with Arriflex 35.

This battery with the 8.4 Volt 8 AH setting is especially desirable for long filming sessions particularly with magazines and torque motor.

LEAD ACID (8 Volt) BATTERIES

These are small storage batteries chemically similar to the usual automobile battery. Initial cost is low, while its service life is between two to three years. Maximum life depends on proper maintenance. A separate trickle charger is available for these batteries. Be sure to read charging and maintenance instructions which accompany each battery, as the life and service of the battery depends upon proper care.

AUTOMOBILE BATTERY

Your Arriflex may be operated from a 6 Volt auto battery in case of need. Maximum camera speed will be approximately 24 FPS. The camera may also be operated from a 12 Volt auto battery provided the battery is tapped for 8 Volts.

DRY CELL BATTERY PACK

Generally, the footage capacity of the storage batteries is more than enough for a day's shooting, and the battery can then be recharged over night. Where this is not possible (on expeditions, etc.) or convenient, the Arriflex can also be run from a dry cell battery pack. (Please write for further information).

HOUSE CURRENT

To use the Arriflex on 110 Volt AC house current, a step-down transformer

rectifier is necessary. An excellent unit of this type is the COMBINATION POWER SUPPLY/BATTERY CHARGER (see separate specifications). It is ideal for indoor shooting and has its own ammeter, volt meter and rheostat built-in. It can also be used to charge lead acid batteries. It must not be used to charge nickel cadmium (Votabloc) batteries.

It is important to remember that with the synch motor camera operation is also possible directly from 110 - 120 Volt, 60 cycle AC power lines.

CAMERA CONTROLS

The motor has a graduated rheostat ring controlling the camera speed, indicated as "frames per second" by the tachometer, which registers up to 50 frames per second. The Arriflex can be run as slowly as 6 frames per second (shooting inanimate subjects under poor lighting conditions) and has continuous speeds up to 50 FPS.

Below the tachometer are the film footage counter and frame counter. Both can be zeroed easily by their respective setting disks.

A knurled disk marked "R" - "F" is located at the back of the motor. When turned all the way to "F" (click-stop), the camera will run Forward; with the disk turned to "R" (click-stop), the camera will Reverse.

As much film as is desired can be reversed, and any frame can easily be located by means of the two counters which register both ways. Caution : both, camera motor and magazine torque motor, must be set to run in the same direction, i.e. BOTH for -ward or BOTH reverse!

The film transport knob in the very center of the motor is used to turn the shutter over by hand for sighting, and to actuate registration pin and film transport claw during loading operation.

OPENING AND LOADING (Please refer to Diagram on Page 9)

Turn cover lock from "C" to "O" and lift off cover. Place 100 ft film spool firmly on upper spindle . Pull off about 2 feet of film.

Open film gate by pressing down on its latch knob and swing the pressure pad assembly open on its hinges. Before threading film, open pressure roller assembly A by pressing button B. Thread film around sprocket drum C. Swing off pressure roller D-1, if necessary. Then arrest film by swinging back pressure roller D-1. Lead film to film gate E by forming a loop according to marking in camera body. Register pin F must be in disengaged position.

INSTRUCTIONS FOR ARRIFLEX 16S

Place film into gate in such a way that a perforation hole is exactly in line with registration pin. Hold film down with two fingers of one hand at both ends of gate and turn transport knob until the registration pin locks film in place. Then close gate. - Thread film around sprocket drum G and close pressure roller D2.

The sprocket spindles have single sprockets only (to permit use of sound perforated film). It is important to seat film properly by moving it back and forth with two fingers over each spindle until you can feel that a sprocket has engaged a perforation. The pressure roller assembly can be rocked on its pivot and so, when the upper sprocket has been threaded, the roller can be rocked to hold film in place. When the lower sprocket has been threaded, the lower portion can, in turn, be rocked into place.

Move a few inches of film through gate by manually turning transport knob at end of motor housing clockwise. Connect camera to battery. Push down internal switch and watch about 2 feet of film roll through camera. (Note: A " 100 ft. roll " of film on a daylight loading spool actually measures 106 feet to permit enough leader and trailer).

Close camera cover and move lock to "C". Be sure that outside switch is released and in open position, as otherwise cover cannot be closed.

Set footage counter and frame counter to "0" by their control disks.

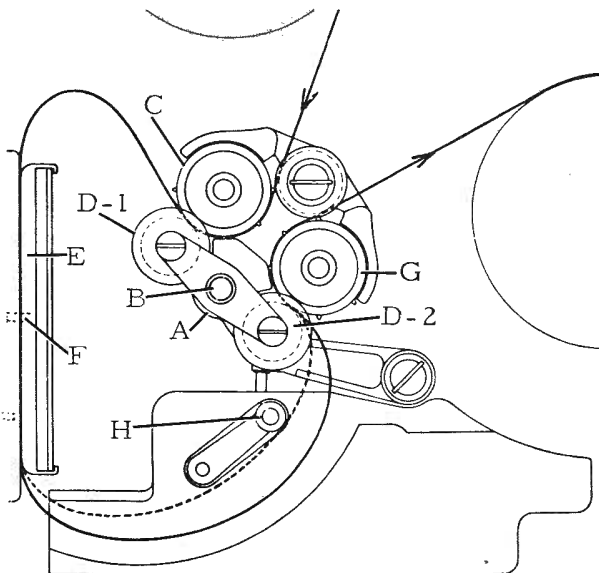

FILM PATH AND LOADING
DIAGRAM

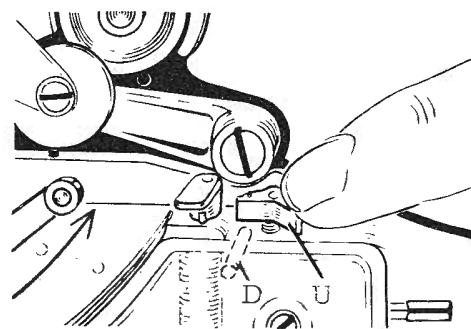

DIAGRAM OF BUCKLE SWITCH
WITH MANUAL OVERRIDE

BUCKLE SWITCH WITH MANUAL OVERRIDE MECHANISM (Please refer to diagram on Page 9).

The buckle switch works properly only if the lower film loop is formed exactly according to the marking in camera body. When end of film has passed film gate, the lower loop softens, thereby pulling up the switch roller H, which in turn cuts off the camera motor. Switching on the camera again is only possible after the pressure roller assembly A has been opened and closed as described in threading instructions. This manipulation, which is always being performed when film is threaded into camera, causes the buckle switch to reset itself. If the pressure roller assembly A is not closed properly, the camera will not start. Any shortening of the lower loop (e. g. film jam in camera) actuates the buckle switch.

IMPORTANT : Never actuate the switch roller H by hand!

The buckle switch override mechanism permits to cut the buckle switch out of the electrical circuit of the camera at the option of the camera operator. Experience has shown that on certain adverse and rare occasions, particularly due to shock or vibration, the micro switch of the buckle switch becomes inoperative, thus switching the camera off. By means of the override mechanism the cameraman in the field can quickly restart the camera without removing the camera door.

In case of doubt whether the buckle switch was unintentionally triggered by impacts or vibration, or whether it was actuated due to a film jam, it is recommended to open the camera cover to check film path and sacrifice a few inches of film rather than use the external override control.

By pressing the push button D below the viewfinder, the buckle switch override mechanism is actuated and the break in the circuit due to the release or the malfunction of the buckle switch is bridged. To reset the buckle switch, the toggle lever U of the buckle switch override mechanism is turned by hand to its initial position, interrupting its overriding function.

FILM GATE

The film gate is extra long (3 inches) and has an oversized rear pressure pad and a side pressure rail. It has cross stages around the picture frame both on front and back plates and "film breathing" is therefore impossible. Made of stainless steel, lapped to high precision and wear chrome-plated, the Arriflex film gate also prevents film scratching.

REGISTRATION PIN FILM MOVEMENT

The registration pin can be seen when the film gate is open just above the transport claw. Its function is to locate the film precisely and hold it in place during the moment of exposure. Thus it ensures rock-steady pictures, a perfect, precise frame line, and accurate trick and animation filming.

FILM TRANSPORT CLAW

The film transport claw engages the film from the lens side, thus making loading easier. Watch its action by turning transport knobs.

MAGAZINE

The top of the camera housing accepts the 400 ft. ARRI magazine. A light-tight cover protects the magazine slot. When the magazine is attached, the cover must first be removed. The camera is ready for magazine operation and has internal wiring to actuate the extra take-up motor, needed with the magazine.

See detailed instructions for attaching and loading the 400 ft. magazine and its torque motor.

DELIVERY AND TAKE - UP SPINDLES

Both spindles have an automatic lock to hold film spool in place in any camera position. To take film spool out, push down button in center of spindle and tilt camera sideways.

The knurled spindle disks on outside of camera serve to take up film slack by turning them in direction of the engraved arrows.

When the film is running, the spindles turn and thus indicate whether film goes forward or backward. When film has run off, the delivery spindle stops turning, thus indicating that the camera is empty.

If between takes the camera is to be transported or stored, it is a good precaution to do the following: After the last take run approximately one or two feet of film through. Before starting to film again, open the camera door and the film gate to see that the claw and registration pin engage the film perforation properly and that it had not slipped during the storage or transport.

TRIPOD SOCKETS

Two tripod sockets, one European and one American type, are provided in bottom of camera housing.

EYELETS

Two eyelets on camera permit use of shoulder strap, supplied with camera, to prevent accidental fall.

CARRYING CASES

Two carrying cases are made for the Arriflex 16. They are especially designed for safe storage and transport of Arriflex cameras. Covered with hammered aluminum, they are red velvet lined and have chrome-plated brass hardware and channeling around cover to insure dustproof, moisture-proof storage. The inside is partitioned to hold camera and accessories safely. A "genuine" Arriflex case is a good investment for the protection of your camera!

Model "A" Case : Accepts camera with 3 lenses, matte box, filters and small accessories.
Size: 15x9x8" - It is designed to fit under an airplane seat.

Model "B" Case : Accepts camera with 3 lenses, matte box, two 400 ft. magazines, torque motor for magazines, shoulder pod, filters and other accessories.

ARRIFLEX SHOULDER POD

This simple but efficient accessory is a **MUST** for the cinematographer who is compelled to shoot hand-held for any length of time. Please refer to the enclosed booklet for more detailed information.

ARRIFLEX PISTOL GRIP

It permits the cameraman to hold the camera and release the shutter with the left hand, while the right hand balances the camera and operates the follow-focus. See detailed description in the enclosed booklet.

COMBINATION PISTOL GRIP / SHOULDER POD

An attractive combination of pistol grip and shoulder pod for maximum hand-held camera stability. Pistol grip has internal trigger switch mechanism to control camera "start" and "stop". For further information see enclosed booklet.

SERVICING AND MAINTENANCE

The Arriflex 16S is built with utmost precision and inherent ruggedness. It will give absolute satisfaction if treated as any precision instrument should be treated, and if serviced at regular intervals, consistent with the amount of use.

The most important rule is :

KEEP CAMERA SPOTLESSLY CLEAN - INSIDE AND OUT !

Particular attention must be given to the film gate. It is precision-lapped and chrome-plated to prevent film emulsion to settle. However, due to the comparatively great length of film gate and pressure plate to ensure maximum film registration, some emulsion deposit is inevitable. This will vary with the type of film used, humidity and other factors.

The film gate should be brushed out at least after every 100 ft. roll and it must be carefully inspected and thoroughly cleaned at least after every 400 ft. roll. Remove emulsion deposit with the plastic skewer supplied with the camera (NEVER METAL). If emulsion is hardened on film gate, remove it with a Q-tip dipped in acetone. Use very little acetone and don't let it touch anything else, as it also destroys paint. After cleaning, polish gently with chamois or other soft material.

From time to time lens mounts and the three lens sockets in turret should be cleaned to remove dirt and dust which will adhere. After such cleaning, re-lubricate lightly with the special grease supplied with the camera.

The lubricants used with the Arriflex are suitable for use in temperatures down to -20° F.

On special request and for extra charge, Arriflex cameras can be winterized at our Service Department to function at still lower temperatures. However, such cameras will have to be normalized again, if intended for use in temperate or hot climates.

OILING

Your camera has been properly lubricated at the factory and is ready for operation. Do not oil before using !

After each run of 30 000 ft. of film through the camera, camera should be lightly oiled at two oil valves marked with arrows (one near the film gate, and one near the spindle). Only use the ball and pressure oiler supplied with your camera and the special oil contained therein. Do not overoil - too much oiling is as bad as too little !

By observing the following "DON'Ts" you will protect the continued operation of your Arriflex :

- DON'T run camera without film at high speeds.
- DON'T attempt to disassemble the optical mechanism . This should be done by factory-trained personnel.
- DON'T touch mirror shutter with fingers. Clean it only with soft camel hair brush. In any case, a spot on the mirror does not affect the picture.
- DON'T mix up covers of different cameras (serial numbers are engraved on each cover and camera).
- DON'T use old or shrunk film; the registration pin's stroke is adjusted to the perforation pitch of fresh film, according to ASA specifications.
- DON'T allow cameras to be serviced in unqualified service shops. Arriflex cameras require special knowledge and experience.
- DON'T neglect to have your camera serviced after approximately every 100 000 ft., or every two years, whichever comes first. Service should be more frequent under adverse conditions.

Our Technical Service Department welcomes your inquiries and is particularly anxious to hear about unusual applications of the Arriflex camera.

GUARANTEE

Arriflex equipment is carefully checked before shipment, and is guaranteed to the original purchaser for a period of ONE year, provided that the registration is filled out and mailed to us within 10 days after date of purchase. The guarantee does not cover damage caused by accident, tam-



pering, or misuse.

Repair and adjustment of Arriflex equipment which may become necessary during the guarantee period because of original defects in material or workmanship, will be made by us without charge if the equipment is sent to us prepaid and properly packed.

Except for such repair or adjustment, Arriflex equipment is sold without warranty or other liability of any kind.

* * * * *

All features and specifications are subject to change without notice.

* * * * *

We have inserted a price list and general literature into this manual, in order to show the new Arriflex owner the many accessories and adaptations which make the Arriflex a "system" camera and enlarge its applications.

* * * * *

ARRIFLEX CORPORATION OF AMERICA

257 Park Avenue South
New York, N. Y. 10010

826 No. Cole Avenue
Hollywood, Calif. 90038